



DEBORAH CHEETHAM FRAILLON AO

PARRWANG LIFTS THE SKY

EDUCATION RESOURCE

Victorian Opera respectfully acknowledges the Traditional Owners of the unceded land on which we work and live: the people of the Eastern Kulin Nation. We acknowledge these original owners and custodians of the lands and waterways and their enduring cultural practices of caring for Country.

We pay respect to their Elders past and present.

CONTENTS

Information for teachers

About the resource

About the work

Synopsis

About the librettist and composer

Workshop 1 – What is opera?

What is opera?

Where did opera come from?

Voice types and singing styles

Composing for opera

Activities

Workshop 2 – Exploring the Culture and Language of the Wadawurrung People

Where is Wadawurrung Country?

Learning Traditional names

Activities

Workshop 3 – Creating the world of *Parrwang Lifts the Sky*

The Set

About Billy-Jay O'Toole

The Painting

The Costumes

About Dr Deanne Gilson Wadawurrung Elder

The Artwork

Activities

Workshop 4 – Meet the orchestra and bump-in

The orchestra

At the theatre

Activities

Appendix A

Appendix B

INFORMATION FOR TEACHERS

Welcome to Victorian Opera's Access All Areas: Livestream Program. This program is built around Victorian Opera's schools production of *Parrwang Lifts the Sky* and is designed for students from Foundation to Grade 6.

Over a series of four livestreamed and ondemand workshops, you and your students will learn all about opera as an art form and many of the production elements required to stage a show, before watching a performance of *Parrwang Lifts the Sky*. This resource supports the four streamed workshops that comprise the program. It includes additional information on the content covered, as well as extra classroom activities to complete each week.

There are a few things you should do to prepare for some of the activities in the livestreamed workshops.

In Workshops 1 - 3, we will be learning how to sing a section of the chorus from the opera, so that we can sing it together with the orchestral accompaniment in Workshop 4. You'll find the sheet music for this chorus in Appendix A on page 27 of this resource, which you can use to get a head start on learning the music or to practice between each workshop.

In Workshop 3, we will meet the director who will teach us how to stage the action. During the workshop, they will ask students watching to get into pairs and follow the directions given

to guide them through a scene. Please have your students divided into pairs before the workshop begins so that they can stand up and participate when asked to do so. The script for this scene is in Appendix B which is on page 31 of this resource.

REPORTING TO OUR FUNDERS

Victorian Opera's Access All Areas: Livestream Program is generously supported by government grants, and philanthropic trusts and foundations. Through our agreement with these organisations, we are required to produce detailed analyses of our activities. Student and teacher feedback is invaluable for this program and helps inform future programming.

To support the work we do, we would be grateful if your students can take a few minutes to complete a few questions following each workshop. The survey links can be found below and will also appear on your screen directly following each workshop.

Workshop 1 – What is Opera? <https://culturecounts.cc/s/5CF8MD>

Workshop 2 – Exploring the Culture and Language of the Wadawurrung People <https://culturecounts.cc/s/5oncfN>

Workshop 3 – Creating the world of Parrwang Lifts the Sky <https://culturecounts.cc/s/2SwAR3>

Workshop 4 – Let's Meet the Orchestra and Bump-in <https://culturecounts.cc/s/4hE3Wj>

We also ask teachers to complete a pre-program and post-program. The survey link will be sent out via email but they are also accessible here:

Pre-program survey: <https://culturecounts.cc/s/3vP8RU>

Post-program survey: <https://culturecounts.cc/s/78dsEP>

If you have any questions related to the program, please don't hesitate to contact Victorian Opera's Education Manager, Tim Ryan on 03 9012 6659 or via email; timr@victorianopera.com.au.

ABOUT THE WORK

SYNOPSIS

Parrwang Lifts the Sky is based on a Wadawurrung creation story about the first sunrise. The Wadawurrung people are from western Victoria in the area from Geelong to Ballarat.

In this story, Parrwang the magpie is preparing for a visit from her cousin Gorngany when she is interrupted by two human children who have climbed her tree.

The humans have been living on the ground which is covered in darkness. They are amazed by the light up in the treetops as they can see all the wonderful colours and feel the breeze. After hearing this from her new friends, Parrwang works to convince the Great Council of Birds, led by Bunjil the Eagle, to lift the veil of darkness from the land. But first she has to convince her cousin and Mr and Mrs Waa, the crows, that the humans can be trusted to share and care for Country.

To the Wadawurrung people, this led to the first sunrise and helped explain the beautiful birdsong sung by magpies at dawn.

THE LIBRETTIST AND COMPOSER DEBORAH CHEETHAM FRAILLON AO



Click on the link below, to read an interview with the librettist and composer of *Parrwang Lifts the Sky*, Deborah Cheetham Frailon AO from 2021. She reflects on the story this opera is based on, and its significance to First Nations' culture.

She also discusses how she has written the libretto and music for the work and the compositional techniques incorporated throughout.

[READ HERE](#)



PARRWANG LIFTS THE SKY



WORKSHOP 1

WHAT IS OPERA?

WORKSHOP 1 – WHAT IS OPERA?

WHAT IS OPERA?

Opera, as a European art form, has been in existence since the 1600s and became especially popular in the eighteenth and nineteenth centuries. Today there are many styles of opera performance, but they all have one thing in common – an opera is a play that is sung.

The predominant languages of opera are Italian, French, German and English.

The main difference between opera and music theatre is amplification: music theatre is usually amplified while opera is not. In addition, music theatre usually includes spoken dialogue as well as music and dance. Opera, on the other hand, uses recitative – a singing style designed to imitate natural speech.

WHERE DID OPERA COME FROM?

The origin of opera can be traced back to the Ancient Greeks who lived over 2,000 years ago. The advances in society that this sophisticated civilisation developed included the invention of a city-state (polis) resulting in a golden age of culture, music, art, poetry and drama, including beautiful sculpture, remarkable architecture and the creation of classical poetry, such as the Iliad and Odyssey of Homer. Ancient Greece had a profound influence on the discovery and

advancement of science, physics, maths, astronomy and geometry, producing the influential philosophers Socrates, Plato, Aristotle and Cicero, who approached the big questions of life often in a genuine scientific way, daring to question and challenge traditional conventions and prejudices of their age. The Ancient Greeks also loved the theatre, with playwrights including Sophocles, Aeschylus and Euripides writing enduring works that informed the future dramatic structures of playwriting.

In the following thousand years, much of the knowledge and skills Ancient Greece had established was lost, particularly in the sciences and arts. For example, the art in what we refer to the Middle Ages had lost some of the scientific application that had made Greek art and sculpture so lifelike. From about the 1300s, Italian scholars set out to rediscover many of the Ancient Greeks' innovations. This period was called the Renaissance, which translates literally as 'rebirth'. Founded in Florence, it marked a period of enlightenment and the rediscovery and study of culture, philosophy, art, architecture and science. Highly influential artists such as Leonardo da Vinci, Michelangelo, Botticelli, Raphael and Donatello; philosophers; writers; and mathematicians including Galileo, Shakespeare, Erasmus and Copernicus contributed a wealth of knowledge during this

era.

One art form the Renaissance scholars were particularly interested in was Greek theatre. The texts had survived time, but the performance practice indications had been lost. Scholars knew from writings by philosophers such as Aristotle and Plato that the plays were accompanied by music and this helped raise the emotional impact of the works. But how? What did the music do? How were the lines sung?

A group of thinkers and musicians from Florence called the Florentine Camerata, met regularly to determine how the musical accompaniment might have sounded and supported the text. They invented a new art form in which the dialogue in a play would be sung. They decided to call the new art form 'Opera', which simply meant 'a work'. The first truly successful opera was called L'Orfeo. It was composed by Claudio Monteverdi and is still performed today.

Following the great success of this work, opera became popular all over Europe and then the world. The style of opera and the way it was performed developed over the centuries to reflect the culture of the time. At its height in the 1800s, opera was performed regularly in theatres in every major city.

VOICE TYPES AND SINGING STYLES

There are seven voice types in opera, each of which is defined by the range of notes they can sing and their vocal quality.

There are three female operatic voice types, although most operas only have soprano and mezzo-soprano roles.

- **Soprano** – the highest sounding female voice with a vocal range from middle C up to the C two octaves above.
- **Mezzo-Soprano** – slightly lower than the soprano with a vocal range from the G below middle C to the A two octaves above.
- **Contralto** – the lowest sounding female voice and rarely used in opera today. The vocal range for this voice type is from the F below middle C to a high F one octave above.

There are four male voice types, although the countertenor voice is mainly used in operas from the Baroque period (1600-1750).

- **Countertenor** – the highest sounding male voice with almost the same vocal range as a mezzosoprano; the G below middle C to a high F one octave above.
- **Tenor** – a high sounding male voice that usually takes the leading male role. The vocal range for this type is roughly from the C below middle C to the C above.
- **Baritone** – the middle sounding male voice with a vocal range from the second G below middle C up to the G above.
- **Bass** – the lowest sounding male voice which has a vocal range from the E above middle C to the E two octaves below; however, some bass singers can sing lower.

Below is a diagram that illustrates where each voice type sits on a music staff.

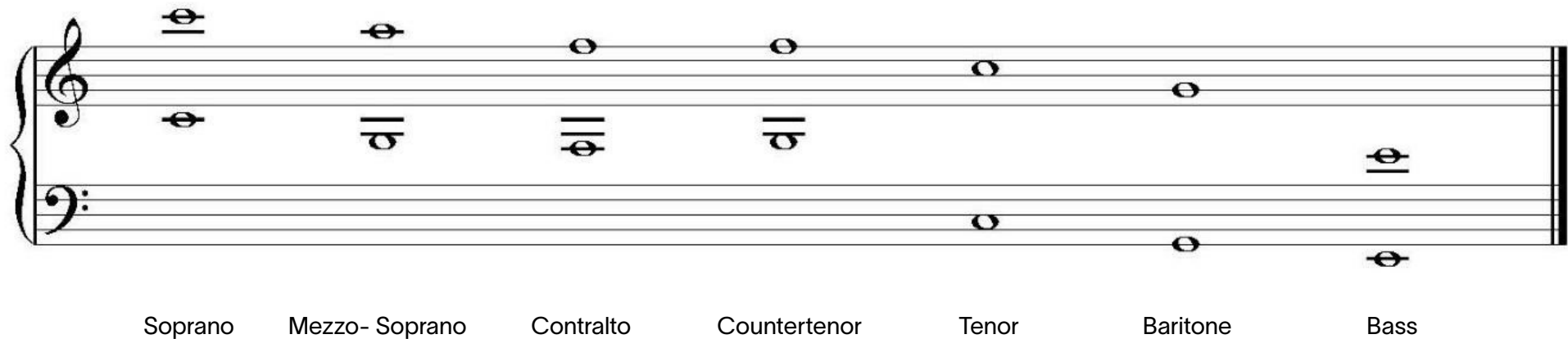

There are further categories of voice defining the kind of voice quality and the type of music they can sing. The composer will consider voice types to highlight the different characters – for example, to differentiate between a King and a Servant, or a Princess and a Witch.

A few of these are:

- **Coloratura** – a very high range with the ability to sing complicated parts with agility.
- **Dramatic** – a heavy sounding, powerful voice.
- **Lyric** – an average sized voice with the ability to sing long, beautiful phrases.
- **Heldentenor** – The ‘heroic tenor’, a very big role that requires a powerful sound.

Follow the links below to hear examples of what these voices sound like:

Classical female voices - <https://www.youtube.com/watch?v=AIPFAww8X-U>

Classical male voices - <https://www.youtube.com/watch?v=gRL7shs23Wc>

Here are the voice types in *Parrwang Lifts The Sky*:

CHARACTER	VOICE TYPE
------------------	-------------------

Parrwang	Soprano
Gorngany	Soprano
Bunjil	Bass/Baritone
Mr Waa	Baritone
Mrs Waa	Mezzo Soprano
Tjatjarrang	Soprano
Koki	Tenor

WORKSHOP 1 – ACTIVITIES

ACTIVITY ONE: SINGING PRACTICE

In Workshops 1, we've been learning to sing a section of the chorus from *Parrwang Lifts the Sky*. Practise singing the first section that we covered in the workshop together as a class.

The music can be found in Appendix A on page 27 of this resource.

ACTIVITY TWO: CAN YOU PICK THE VOICE TYPE?

Play your students sections of the link below, as per the time indications provided alongside each voice type listed, and ask them to name the voice type they hear.

Information on the voice types listed below can be found on page 8 of this resource.

Listen here: <https://www.youtube.com/watch?v=hLfvkwTnJVM>

Soprano: 1"31'-2"27'

Mezzo-Soprano: 4"54'-5"56

Countertenor: 4"28'-4"53'

Tenor: 3"28'-4"27'

Baritone: 0"56'-1"30'

Bass: 2"28-3"27

Helpful hint: Make sure your students can't see the video as it gives away the answers!

ACTIVITY THREE: COMPOSITION FUN

Ask your students to come up with a rhythmic pattern the length of a 4/4 bar.

Once everyone has prepared their rhythms, stand in a circle and ask everyone to clap their rhythm out one at a time. Start with the teacher and go clockwise. Try and complete this activity so there's no space between each person's rhythm.

If you'd like to hear it back, record the activity with an audio recorder and play it back to the class.

To make this activity more challenging, repeat it with a composed melodic pattern in place of the rhythmic pattern.

ACTIVITY FOUR: COMPREHENSION AND RESEARCH WORKSHEET

Working in pairs, read the section below about what opera is and then answer the questions. When you have completed the comprehension questions research what Chinese Opera is.

Opera, as a European art form, has been in existence since the 1600s and became especially popular in the eighteenth and nineteenth centuries. Today there are many styles of opera performance, but they all have one thing in common – an opera is a play that is sung. The main languages that are sung in opera are Italian, French, German and English.

The main difference between opera and music theatre is amplification: music theatre is usually amplified while opera is not. In addition to singing, music theatre usually includes spoken dialogue and dance. Opera, on the other hand, uses recitative--a singing style designed to imitate natural speech.

1. When did European Opera begin to develop?

2. What is an opera?

3. What are the main languages that are sung in opera?

4. What is recitative?

5. List the 2 differences between Musical Theatre and Opera

Research

There is an even older form of opera called Chinese Opera. Continue working with your partner, go to https://en.wikipedia.org/wiki/Chinese_opera and find out when Opera began in China.

Colour is very important when design costumes and make-up in Chinese opera, from the same webpage, find out what the following colours represent in Chinese Opera.

- **Red** means
- **Black** means
- **White** means
- **Blue** means
- **Yellow** means
- **Purple** means
- **Green** means
- **Gold and silver** means

Which of the colours above would Parrwang have in her costume if *Parrwang Lifts the Sky* was performed as a Chinese Opera??



PARRWANG LIFTS THE SKY

WORKSHOP 2

EXPLORING THE CULTURE OF THE
WADAWARRUNG PEOPLE

THE STORY

The story of *Parrwang Lifts the Sky* comes from the oral history of the Wadawurrung people.

Wadawurrung Country covers over 10,000 square kilometres from the Great Dividing Range in the North, to the coast in the south, from the Werribee river in the east, and to Aireys Inlet in the west, and includes Geelong and Ballarat.

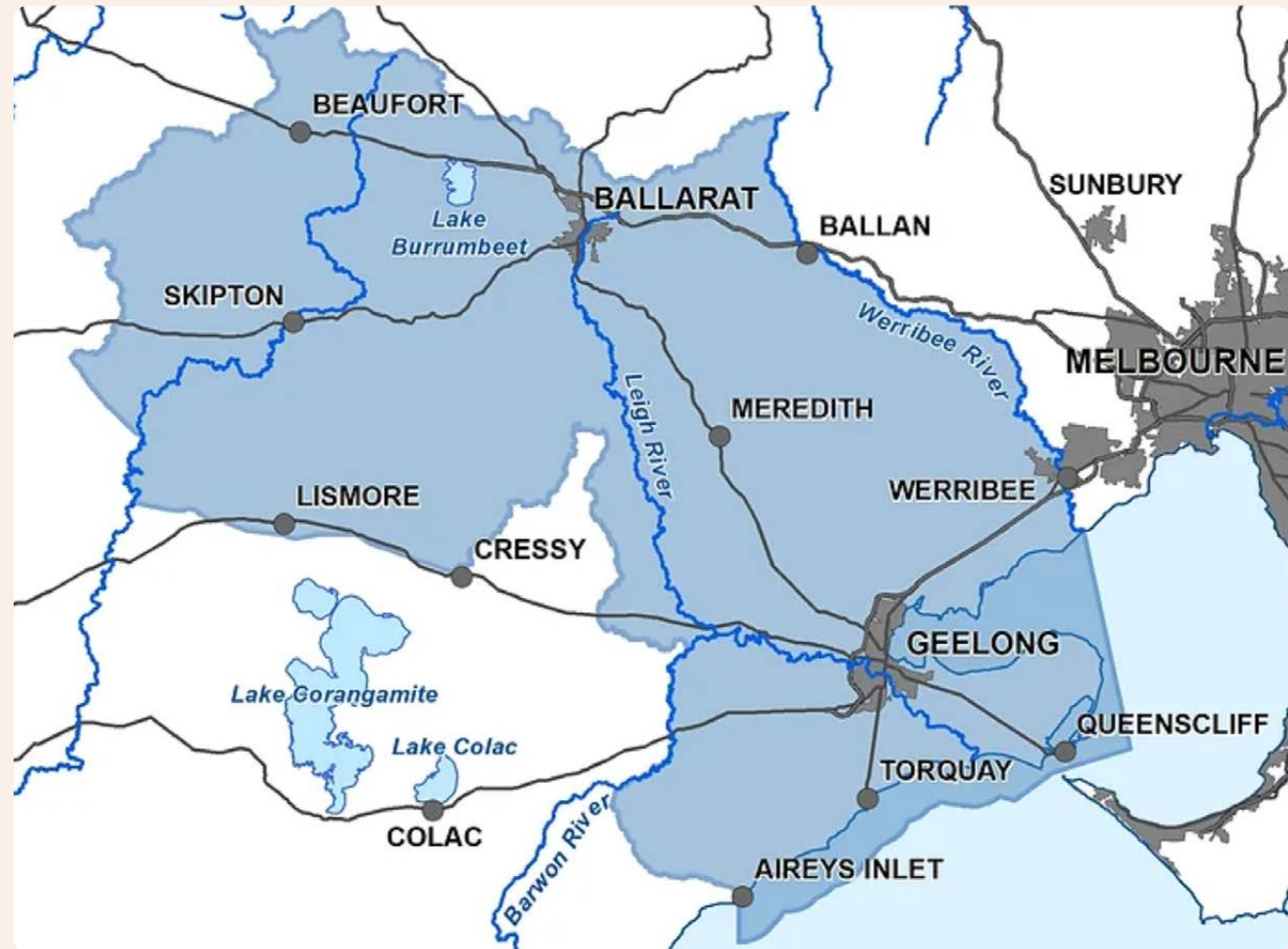

LEARNING TRADITIONAL NAMES

The below short videos are a great resource to learn more about Wadawurrung country and language.

WURDI YOUANG - <https://www.youtube.com/watch?v=PGEJOSaeCJQ>

BOROMBEET - <https://www.youtube.com/watch?v=xB8CepJhTQ8>

WARRENYEEP - <https://www.youtube.com/watch?v=wjMiNprafQk>

LAL LAL - https://www.youtube.com/watch?v=hASQdr_SADk

KAREET BAREET - <https://www.youtube.com/watch?v=MLjJbjz2JN8>

BALLAARAT - <https://www.youtube.com/watch?v=zE5tXccmF9c>

BONAN YOUANG - <https://www.youtube.com/watch?v=o-aDjhooGYM>

MODEWARRE - <https://www.youtube.com/watch?v=mNGsFbmbYaE>

KUARKA DORLA - <https://www.youtube.com/watch?v=XYrso-UcEJk>

SCAR TREES AND WADAWURRUNG PEOPLE - <https://www.youtube.com/watch?v=JzCrDTqgYiA>

BELLS BEACH, WADAWURRUNG COUNTRY - <https://www.youtube.com/watch?v=eaTdiEMD3g>

Want to learn more about Wadawurrung Culture and Language? The Wadawurrung Traditional Owners Corporation have great resources on their website including the Wadawurrung Healthy Country Plan about caring for Country <https://www.wadawurrung.org.au/healthy-country-plan-video>

WORKSHOP 2 – ACTIVITIES

ACTIVITY ONE: SINGING PRACTICE

In workshop 2, we continue to learn to sing the final chorus from *Parrwang Lifts the Sky*. Practice singing the first and second sections that we have covered in workshops 1 and 2 together as a class.

The music can be found in Appendix A on page 27 of this resource.

ACTIVITY TWO: WHAT COUNTRY ARE YOU ON?

If you don't know already, find out what country you live on.

Once you've discovered the name of the country you live on, do some research to learn about any characteristics particular to the culture.

As cultural history and practices are passed on through oral tradition, many resources have been created using film and TV. Use the ABC Indigenous channel on YouTube (<https://www.youtube.com/channel/UCeL4bsWHfMBloaPTIQDC64g>) to conduct some of your research.

ACTIVITY THREE: CONNECTING WITH COUNTRY

Watch the videos about Wadawurrung country and language on page 14 of this resource then have a discussion as a class about what you learnt and what connects Wadawurrung people to country.

ACTIVITY FOUR: STORYTELLING

Parrwang Lifts the Sky comes from the oral history of the Wadawurrung people and tells the creation story of the first sunrise. The story has been passed on through storytelling from one generation to the next.

Do some research and find out if the tradition of storytelling exists in your own cultural heritage.

If so, share a story that you've been told with the rest of the class.

If not, what traditions are important in your own cultural heritage that teach you about who you are and where you come from.

PARRWANG LIFTS THE SKY



WORKSHOP 3
DESIGNING THE WORLD OF
PARRWANG LIFTS THE SKY

An important element of any theatre production is the set and costumes because they help shape the world the story is based in and make it easier for audiences to engage with the performance.

For *Parrwang Lifts the Sky*, Mel Serjeant designed the setting and the costumes using artwork provided by Wadawurrung artists Billy-Jay O'Toole and Dr Deanne Gilson Wadawurrung Elder

THE SET

The design for the set includes elements of a painting created by Billy-Jay O'Toole. Read more about the artist and his painting below.

ABOUT BILLY-JAY O'TOOLE



My name is Billy-Jay. I'm a proud Wadawurrung man residing on Wadawurrung country in Mount Duneed. I was born and raised on Wadawurrung country in Geelong. I am a recognised Traditional Owner and member of the Wadawurrung Traditional Owners Aboriginal Corporation, where I work as a Cultural Heritage Representative.

In 2019, I completed my Certificate IV in Cultural Heritage Management enabling me to strengthen my cultural commitment to my country and community whilst also strengthening my cultural connection to family and country. Working on my country reignited my spirit of painting, walking country and learning from country in my Field Officer role and I now work in my gift of storytelling through paint, of which I have created many stories of country.

I am on a journey learning language and I like to connect this to my paintings and stories of Wadawurrung Country. My art style is a contemporary style, always reflecting the stories and colours of Wadawurrung Country. With the use of bright and earthy colours and symbols, as well as the elements of country, water, mountains, sun and coast – all of which give us what we need to live. I have established a social media page for my art called Papul Art. "Papul" is the Wadawurrung language name for Ochre, which is traditionally used for painting by Wadawurrung people.

THE PAINTING – PARRWANG

Parwang is the Wadawurrung name for magpie. Parwang loves to sing on his own or with a group of parwangs. When walking along our coast you will see and hear parwang in the dunes, walking around our rivers and mountains you find parwang in our biyal (redgums). Listen to parwang as the dark sky lifts for the morning sunrise.

Elements included in the painting from the bottom:

- Sand dunes
- Coastal water
- Mountains/trees
- 'U' shapes running through the middle symbolise people gathering
- Yellow dots symbolise a field of yam daisies which were grown and harvested by Wadawurrung women
- Rivers/creeks
- Stony rise/rocky outcrop



THE COSTUMES

The costumes designed for the characters in this work have incorporated elements from a series of artworks created by Dr Deanne Gilson Wadawurrung Elder. Read more about the artist and view images of her artwork below.

ABOUT DR DEANNE GILSON WADAWURRUNG ELDER



Deanne Gilson is a proud Wadawurrung woman living on her ancestral Country of Ballarat in Victoria.

Gilson's thirty-seven year art practice aims to highlight and bring back traditional women's symbols and ceremonial practices that reference the lived experience of her ancestors, by reviving traditional marks found on artefacts. This allows her to form links with past ancestral knowledge so that it is not lost and continues for the future generations. Using symbols and form as a metaphor for the body, Gilson paints them onto fabric designs and artworks.

stories and Songlines, creating contemporary art and designs that are linked to the past.

A main focus of Gilson's art practice tells the Creation Story through birds, native flowers, feather patterns, birthing trees and scar tree stories, further revealing how Wadawurrung women have evolved and survived, since before and after colonisation. The old symbols find new life, connecting to the contemporary ones, which are all deeply connecting to Country, spirit, the sky knowledge, tree knowledge and under Country. All are connected and assists her in living a sustainable life that continues her culture today.

THE ART

Many designs tell stories of the spiritual aspects of her culture, through Dreamtime



WORKSHOP 3 – ACTIVITIES

ACTIVITY ONE: SINGING PRACTICE

In workshop 3, we continue to learn to sing the final chorus from *Parrwang Lifts the Sky*. Practice singing all of the sections we have learnt across the 3 workshops.

The music can be found in Appendix A on page 27 of this resource.

ACTIVITY TWO: WHAT DO YOU SEE?

To complete this activity, turn to page 19 of this resource and ask your students to look closely at the images of Deanne's artwork.

Then, have a conversation with your class about what they see and how they think these artworks have been incorporated into the costume designs for *Parrwang Lifts the Sky*.

ACTIVITY THREE: ACTING LIKE A BIRD

As you'll discover when you watch a performance of *Parrwang Lifts the Sky*, many of the characters on stage are birds. If you were performing in this work, what are some characteristics of the magpie, crow or eagle you would incorporate into your performance?

Spend some time reflecting on how each of the above-mentioned birds move and hold themselves, then practice moving around and embodying a bird. Go up to a fellow classmate and interact with them as if you were a bird.

ACTIVITY FOUR: EXPLORING REACTIONS

Find a buddy and decide which of you will play the role of Koki and Tjatja.

Using your voice, body, movement and language, explore the different ways you would react to experiencing the below situations for the first time. As Koki and Tjatja are siblings and are experiencing the situation together, be sure to interact with each other.

- **A bright, blue sky and the feeling of air and wind on your face**
- **A talking bird**
- **Seeing the sunrise for the first time**

Then, pick your favourite reaction and perform it to the rest of your class.

ACTIVITY FIVE: RECREATE A SCENE

Working in pairs to recreate a scene from *Parrwang Lifts the Sky*, the script for this activity is provided in Appendix B of this resource. Just say the lines, no need to sing them.

- 1) As a class, review the key points about directing a scene that Elizabeth spoke about in the workshop.
- 2) Then in your pairs, read through the script.
- 3) Assign who will play Mr Waa and who will play Mrs Waa
- 4) Work together to stage the scene thinking about your positions, movements, gestures, and facial expressions.
- 5) When it's ready, perform it to the rest of your classmates.

Remember to consider the key points about directing a scene that Elizabeth spoke about so that what you perform makes sense to the audience.

PARRWANG LIFTS THE SKY



WORKSHOP 4
MEET THE ORCHESTRA &
TIME TO BUMP-IN

The orchestra is one of the important elements of opera. Some operas can call for an orchestra of up to 100 musicians, while others only call for a smaller group, also known as a chamber orchestra.

The orchestra for *Parrwang Lifts the Sky* is a chamber orchestra and is made up of 14 musicians. Look at the table below to see what instruments are used and the instrument families they come from.

INSTRUMENT	INSTRUMENT FAMILY
Violins	String family
Viola	
Cello	
Double Bass	
Piccolo	Woodwind family
Flute	
Oboe	
Cor Anglais	
Clarinet in Bb and A	
Bass Clarinet	
Bassoon	
French Horn	Brass Family
Piano	Keyboard family
Glockenspiel	Percussion family
Suspended Cymbal	
Timpani	
Triangle	

AT THE THEATRE

BUMPING IN THE SET

When the set is installed in either the rehearsal room or on the theatre stage, the process is called a 'bump-in'. Similarly, when the set is taken out of either of these venues, the process is called a 'bump-out'.

In the case of *Parrwang Lifts the Sky*, which is being performed in the Merlyn Theatre at Malthouse, the set will be bumped-in three days before the opera's first performance. Once the set and lighting are installed, the cast, creative team and orchestra rehearse the work to practice in the performance space, which usually differs quite a bit from the rehearsal space.

The rehearsal process inside the theatre usually follows the following order:

Piano technical rehearsal

This rehearsal is for the stage managers who have the chance to run through the opera to make sure all the technical cues and cast entrance and exit cues are correct. This rehearsal is accompanied by a piano.

Sitzprobe

The sitzprobe is, translated literally, a 'sitting down rehearsal'. It is the first time the cast come together with the orchestra and sing through the opera without having to wear their costumes or perform any of their actions.

Piano dress rehearsal

The piano dress rehearsal is a dress rehearsal for all the cast and stage management crew to run through the production. The cast are dressed in their costumes and are accompanied by the piano.

Stage orchestral rehearsal

The stage orchestral rehearsal is the first time the cast and orchestra come together to rehearse the work on stage. The cast are usually in costume and will perform all their actions.

General rehearsal

The general rehearsal is the final run through of the opera before its first performance. The cast are dressed in their costumes with full hair and makeup and are accompanied by the orchestra. Sometimes a small audience is in attendance at these rehearsals, which gives the rehearsal more of a performance feel.

WORKSHOP 4 – ACTIVITIES

ACTIVITY ONE: SINGING PRACTICE

Across the four workshops, we've learnt to sing a section of the chorus part from *Parrwang Lifts the Sky*. Keep practicing the excerpt so you can sing along with the cast members and orchestra during the performance.

The music can be found in Appendix A on page 27 of this resource.

ACTIVITY TWO: LEARN THE INSTRUMENTS' SOUNDS

Listen to the sound each of the instruments listed below make using Melbourne Symphony Orchestra's Learn app. To access the app, visit <https://msolearn.com.au/>

Violin	Harp	Percussion
Viola	Oboe	
Cello	Clarinet	

ACTIVITY THREE: NAME THE INSTRUMENT

Play each link listed below and ask your students to name the instrument.

Violin - <https://www.youtube.com/watch?v=fS-8J5pa2AQ>

Viola - https://www.youtube.com/watch?v=0xtk_SPv7y0

Cello - https://www.youtube.com/watch?v=uUUBo-8_8Jo

Harp - https://www.youtube.com/watch?v=uO_fbJ86Xc8

Oboe - https://www.youtube.com/watch?v=S7FaQrETz_w

Clarinet - <https://www.youtube.com/watch?v=hnO9EML6wAs>

Percussion - https://www.youtube.com/watch?v=qD_TpWfbag8

ACTIVITY FOUR: WHAT DO THE INSTRUMENTS LOOK LIKE WORKSHEET

On page 23 of this resource is the list of instruments in the orchestra for *Parrwang Lifts the Sky*. Find those instruments and circle them in the picture below, using a different coloured pencil for each instrument. NB: Not all of them are in the picture.

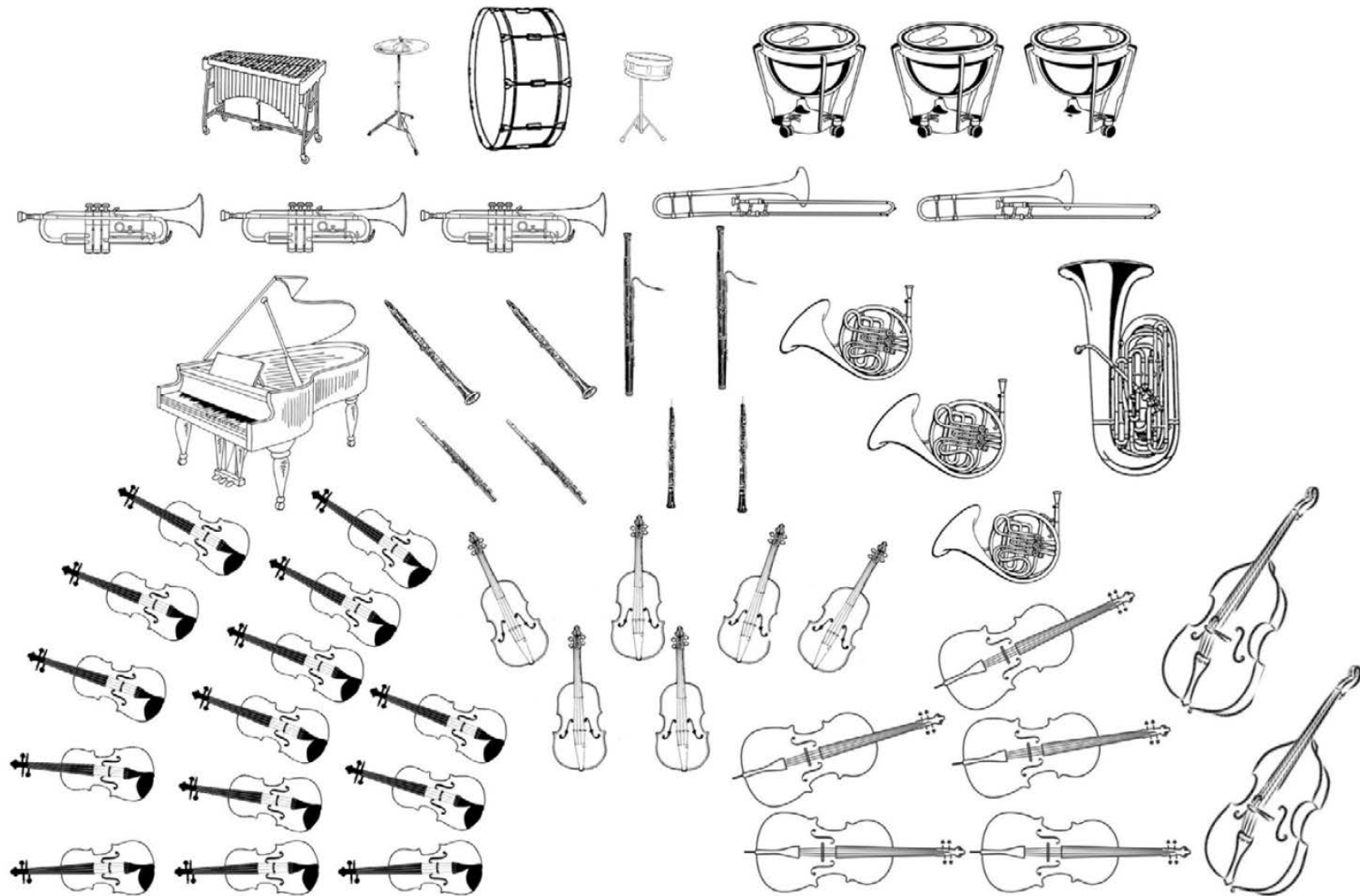

APPENDIX A

Use the music provided below to practice each section of the chorus excerpt from *Parrwang Lifts the Sky* that you learn each week.

Listen to the music [HERE](#).

Magpie Chorus

Parrwang Lifts the Sky

Deborah Cheetham Fraillon AO

A

$\text{♩} = 100$

As we lift the sky we will sing a song in the an - cient lan-guage of the

Piano

B

5

Wa-da - wur-rung

Woorr - woorr

Pno.

10

The sky split open, showing the beauty of the first sunrise

tyoorr-koorr-ma wer-up-me-ring we-ne-ring-ik yer-ram ngan-boo Kar - di - ne - yoo -

Pno. *mf* *cresc.*

15

- Mir-ri-yu nyall darra-dyalk

Pno.

19

C

tyoorr-koorr-ma wer-up-me-ring we-ne-ring-ik yer-ram ngan - boo

mf *cresc.* *f* *cresc.*

22

To this day Parrwang and her family greet the sunrise with their joyful song

Mat nyoo yer - ram Par-wan wa-ya-per-ree kar-di-ne-yoo beng - go - ee - tha-nang yer - ra yer - ra yeng yeng!

ff *fff*

APPENDIX B

Use the excerpt provided below from Victorian Opera's production of Parrwang Lifts the Sky to complete 'Activity five: Recreating a scene' after you watch Workshop 3.

Assign the characters to different people in your group and work together to stage the scene.
When it's ready, perform it to the rest of your classmates.

SCENE 3 - MR AND MRS WAA
Mr and Mrs Waa land in Parrwangs tree

Mr Waa: My dear Mrs Waa
(Bows to Mrs Waa)

Mrs Waa: My dearest Mr Waa
(Bows to Mr Waa)

(Now looking at each other)

Mr Waa: How splendid you look

Mrs Waa:How very handsome you are

Mr Waa: (facing the audience and spreading arms as if a bird in flight) If my feathers are gleaming it's because of your preening (Mrs Waa stands behind Mr Waa and dusts down his costume)

Mrs Waa: You are far too kind, and I really don't mind (Mrs Waa steps to the right of Mr Waa) for it's wonderful to look the way we do.

Mr and Mrs Waa: and it's (step right foot forward) wonderful to share
(Sweep right arm up) the sky with you.



The Marian & E.H. Flack Trust

William Angliss Charitable Fund

Victorian Opera acknowledges the support of The Department of Education and Training, Victoria, through the Strategic Partnerships Program.

Presenting Partner

In association with

